

SILICON BRIDGE RECTIFIERS

Features

- ◆ The plastic package carries Underwriters Laboratory Flammability Classification 94V-0
- ◆ Ideal for printed circuit boards
- ◆ Low reverse leakage
- ◆ High forward surge current capability
- ◆ High temperature soldering guaranteed: 260°C/10 seconds, 5 lbs. (2.3kg) tension

Mechanical Data

Case : JEDEC KBPC-25W Molded plastic body

Terminals : Solder plated, solderable per MIL-STD-750, Method 2026

Polarity : Polarity symbol marking on body

Mounting Position : Any

Weight : 0.93 ounce, 26.4 grams

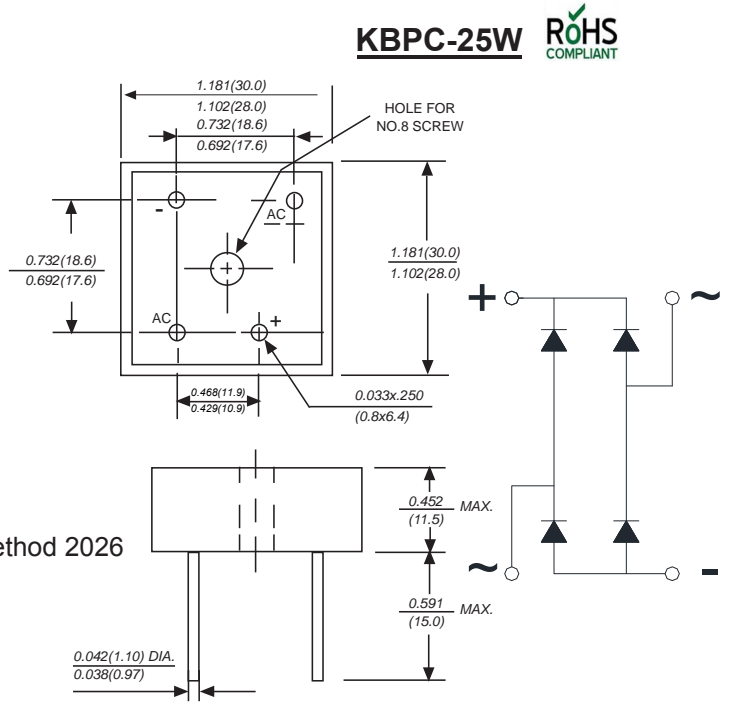

Dimensions in inches and (millimeters)

Maximum Ratings And Electrical Characteristics

Ratings at 25°C ambient temperature unless otherwise specified.

Single phase half-wave 60Hz, resistive or inductive load, for capacitive load current derate by 20%.

Parameter	SYMBOLS	MDD KBPC25005W	MDD KBPC2501W	MDD KBPC2502W	MDD KBPC2504W	MDD KBPC2506W	MDD KBPC2508W	MDD KBPC2510W	UNITS
Marking Code									
Maximum repetitive peak reverse voltage	V_{RRM}	50	100	200	400	600	800	1000	V
Maximum RMS voltage	V_{RMS}	30	70	140	280	420	560	700	V
Maximum DC blocking voltage	V_{DC}	50	100	200	400	600	800	1000	V
Maximum average forward output rectified current at $T_c=55^\circ\text{C}$ (Note 1)	$I_{(AV)}$	25.0							A
Peak forward surge current 8.3ms single half sine-wave superimposed on rated load (JEDEC Method)	I_{FSM}	300							A
Rating for Fusing ($t < 8.3\text{ms}$)	I^2t	373							A^2s
Maximum instantaneous forward voltage drop per bridge element at 12.5A	V_F	1.1							V
Maximum DC reverse current $T_A=25^\circ\text{C}$ at rated DC blocking voltage $T_A=100^\circ\text{C}$	I_R	10							μA
		1.0							mA
Isolation voltage from case to leads	V_{IOS}	2500							V_{AC}
Typical Thermal Resistance (Note 2)	$R_{\theta JA}$	2.0							$^\circ\text{C}/\text{W}$
Operating junction temperature range	T_J	-65 to +150							$^\circ\text{C}$
storage temperature range	T_{STG}	-65 to +150							$^\circ\text{C}$

NOTES:

- Unit mounted on 5" x 6" x 4.9" thick (12.8cm x 15.2cm x 12.4cm) Al. plate.
- Bolt down on heat-sink with silicone thermal compound between bridge and mounting surface for maximum heat transfer efficiency with #8 screw.

Ratings And Characteristic Curves

AVERAGE FORWARD RECTIFIED CURRENT, AMPERES

FIG. 1- FORWARD CURRENT DERATING CURVE

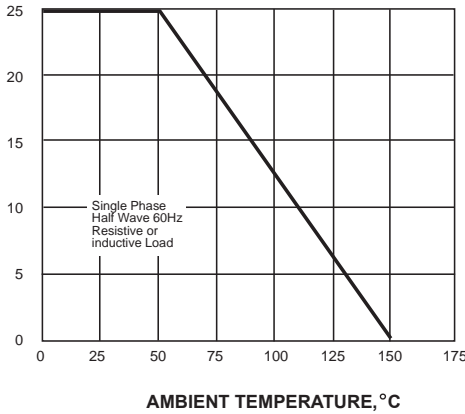

PEAK FORWARD SURGE CURRENT, AMPERES

FIG. 2-MAXIMUM NON-REPETITIVE PEAK FORWARD SURGE CURRENT

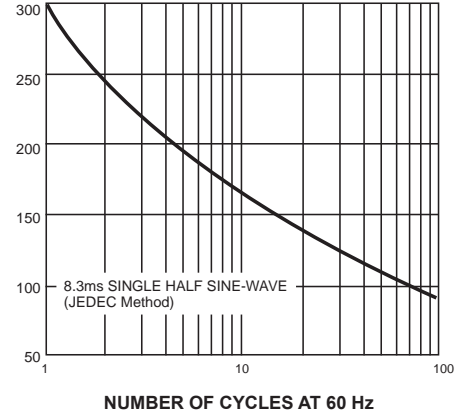
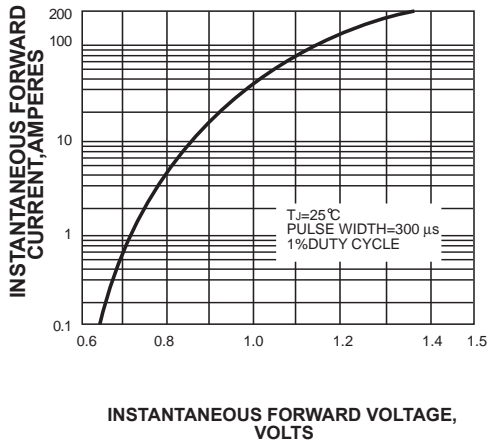

FIG. 3-TYPICAL INSTANTANEOUS FORWARD CHARACTERISTICS



INSTANTANEOUS REVERSE CURRENT, MICROAMPERES

FIG. 4-TYPICAL REVERSE CHARACTERISTICS

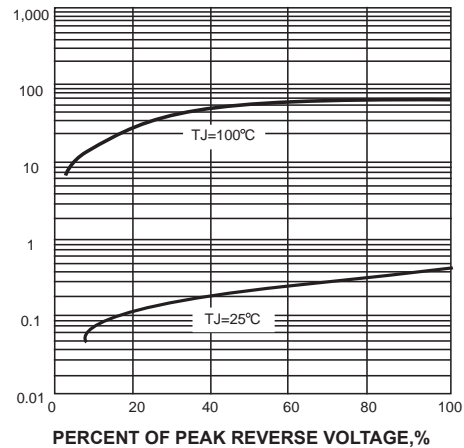
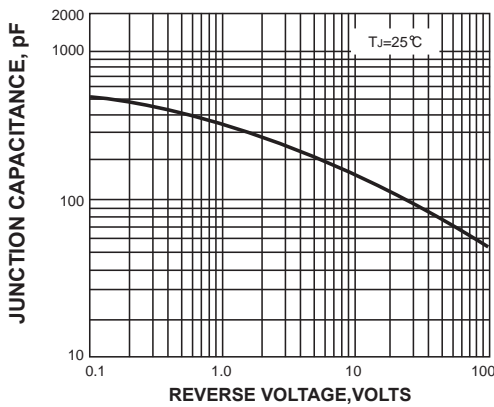
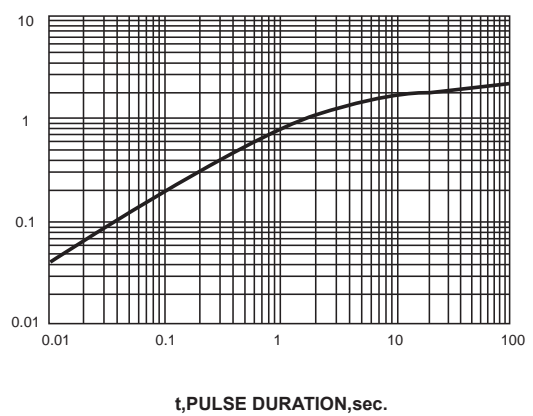

FIG. 5-TYPICAL JUNCTION CAPACITANCE



TRANSIENT THERMAL IMPEDANCE, °C/W

FIG. 6-TYPICAL TRANSIENT THERMAL IMPEDANCE



The curve above is for reference only.